



# WEATHER SHIELD® COLLECTION

**WEATHER SHIELD®**  
WINDOWS & DOORS

YOUR DESIGN. YOUR VISION.

# IN FULL VIEW





# VUE

COLLECTION®

Modern design. Seamless engineering. The ultra-modern, all-aluminum VUE Collection makes sure nothing stands in the way of your home or your view.

---

The modular design of the VUE Collection is completely customizable. Windows can be combined easily to create walls of glass with ultra-narrow profiles, making the boundary between indoors and outdoors practically vanish.



THE BEST POINTS OF VUE



## Ultra-Narrow Profiles

Maximize every view with super-thin profiles and industry-leading sizes that connect indoor living spaces with the outdoor spaces around them.

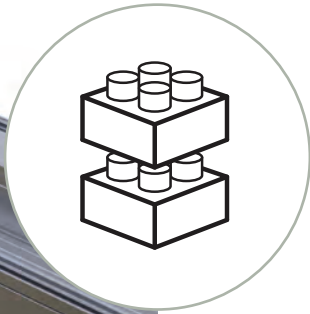
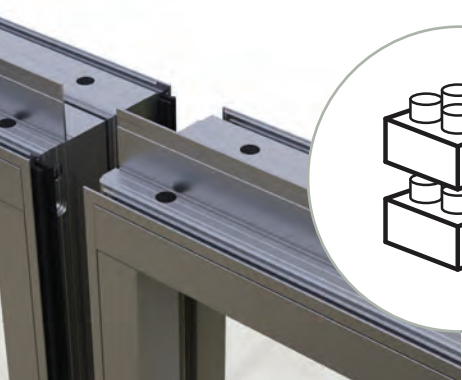

## Integrated System

All VUE Collection products seamlessly connect with one another to create custom combinations of glass walls.



## Design Flexibility

Every home design is unique. That's why we offer more options to help you achieve your vision. Match your architectural style with one of three distinct exterior aesthetics or choose that perfect bespoke color.



## High-Performance Engineering

Each product is designed to maximize thermal and structural performance with the narrowest possible profile. With advanced polyamide thermal breaks, the VUE Collection is engineered to perform.

# O V E R V I E W

## INSPIRED FORM. UNCOMPROMISED FUNCTION.

Unique structural integrity supports massive expanses of glass with ultra-narrow profiles while providing the exceptional thermal qualities of engineered aluminum.

Every window in the VUE Collection features thermally-broken aluminum to withstand the most severe weather conditions. The polyamide thermal breaks significantly reduce temperature transfer to deliver industry-leading thermal performance.

Get the look you've been longing for without sacrificing the performance you expect. Available in three distinctive form factors, the range of styles works with any home: Square Bead, Narrow Bead, and Beveled Bead.

### CONSISTENT PROFILES

Fixed and operating units can be connected with a unique interlocking frame system.

### NARROW SIGHTLINES

Allow for maximum views while still providing structural support for even the largest pieces of glass.



### THERMAL INTEGRITY

#### EXTERIOR

Withstands the most severe conditions.

#### INTERIOR

Keeps things comfortable without wasting energy.

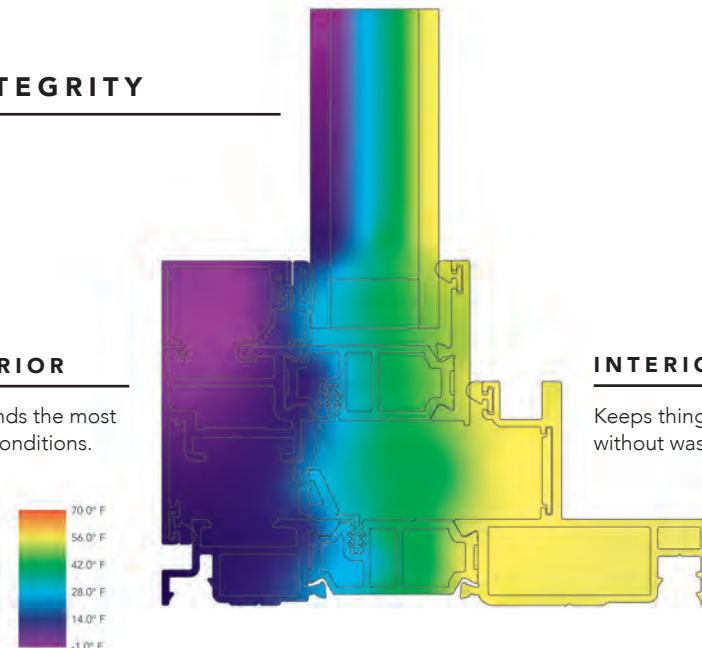



## BALANCED

### SQUARE BEAD

#### AESTHETIC

---

Modern design features clean, squared-off edges.

#### CONSTRUCTION

---

Precision butt-joined corners provide a consistent, polished look.

#### COMMON USE

---

Best for modern designs where balanced sightlines outweigh narrow proportions.



## MINIMALISTIC

### NARROW BEAD

#### AESTHETIC

---

An ultra-narrow sightline hides to accentuate the spans of glass.

#### CONSTRUCTION

---

Precision butt-joined corners provide a consistent, minimal look.

#### COMMON USE

---

Modern applications where narrow features and unobstructed views take precedence.



## GRACEFUL

### BEVELED BEAD

#### AESTHETIC

---

A soft appearance that highlights narrow profiles without sharp lines.

#### CONSTRUCTION

---

Precision miter corners deliver crisp, gap-free visuals.

#### COMMON USE

---

Soft-modern or transitional designs.

# DIRECT-SET

## MINOR PROFILES. MAJOR VIEWS.

An ultra-narrow profile maximizes views and natural light.

---

With one of the narrowest profiles available, our direct-set windows offer an ultra-narrow 2-11/16" mullion when combined with other direct-sets. They are available on their own or can seamlessly connect to other products and styles with our innovative mullion system.



Image Courtesy of Ryann Ford Photography



### EXTERIOR GLAZING BEAD

Precision-cut joints minimize gaps. Three distinct profiles can complement any design aesthetic.

### INNOVATIVE MULLION SYSTEM

Easily connect multiple windows to one another to create a seamless wall of glass.

### INTEGRATED WEEP CHANNEL

A full-length kerf at the sill provides drainage without unsightly weep gates or exposed holes.

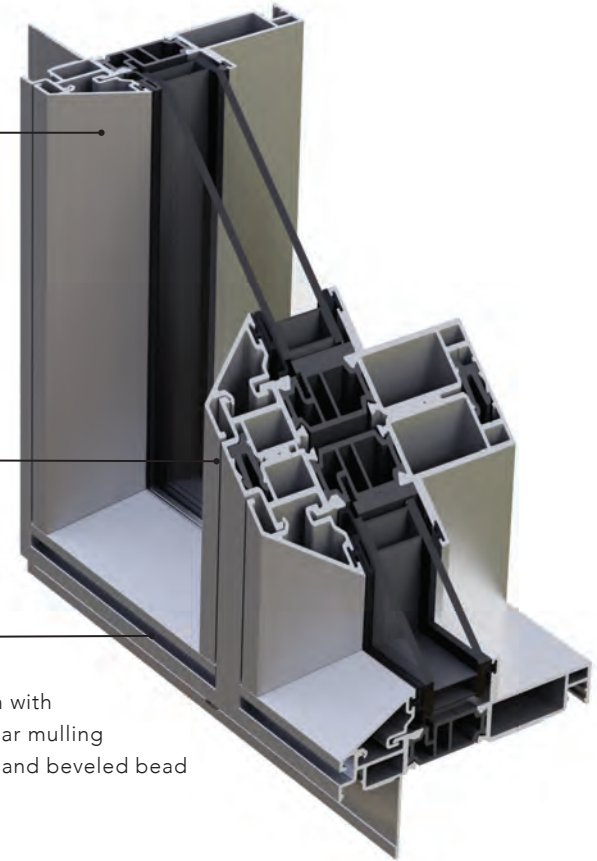

Shown with modular mullion frame and beveled bead



Shown with square bead

### REFINED INTERIOR PROFILES

Thoughtfully simple interior profiles draw the eye to the view, not the framing.

### 5/8" JAMB FRAME

The narrow jamb face easily disappears into surrounding wall materials.

### THERMALLY-BROKEN DESIGN

Advanced polyamide thermal strut is designed to deliver optimal thermal and structural performance capable of meeting the most stringent codes in North America.

## 90° CORNER

MORE GLASS.  
LESS DISTRACTION.

Add drama to the corners of your home design by opening up to more glass. The narrow corner post of the 90 degree corner window gives more view and less distraction.

Create large ribbons of glass that maximize available views. Options such as three distinct glazing beads and a range of anodized and paint finishes offer the ability to create a tailored aesthetic.



Image Courtesy of Ryann Ford Photography

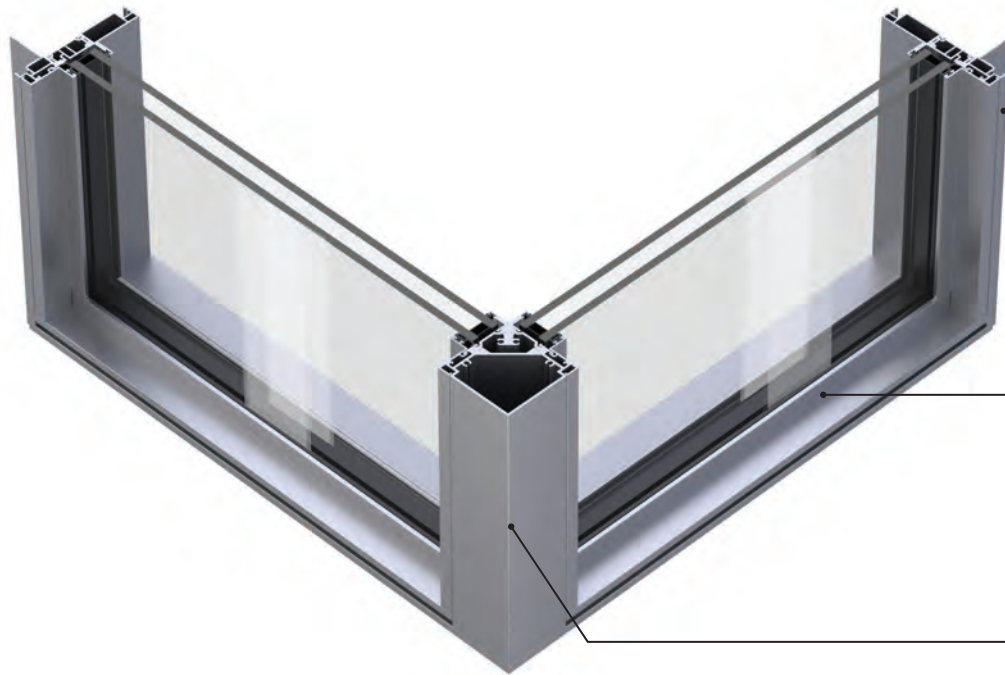

---

### ULTRA NARROW FRAME

The 1-5/16", narrow direct-set frame maximizes the amount of visible glass making the view the center of attention.

---

### THREE DISTINCT GLAZING BEAD OPTIONS

Exterior frames can be accented by one of three distinct glazing bead profiles. The chosen style can be coordinated throughout all VUE Collection products.

---

### ADVANCED THERMAL FRAME DESIGN

All frame components, including the corner post, utilize an advanced polyamide thermal break to improve thermal efficiency and overall comfort.

---

### COMPLETE CORNER ASSEMBLY

Corner windows come as a complete, fully glazed system. No field assembly required. Units can be mullioned and stacked.



# C A S E M E N T

## LET IN THE VIEWS AND THE BREEZES.

Generous views and wide-open ventilation. Our casement windows offer one of the narrowest sightlines in the industry to deliver more visible glass.

---

Industry-leading sizes and completely concealed hinges allow sashes to open with the cleanest interior and exterior aesthetic possible. They also seamlessly connect to other products and styles to help keep your space comfortable and energy-efficient year-round.



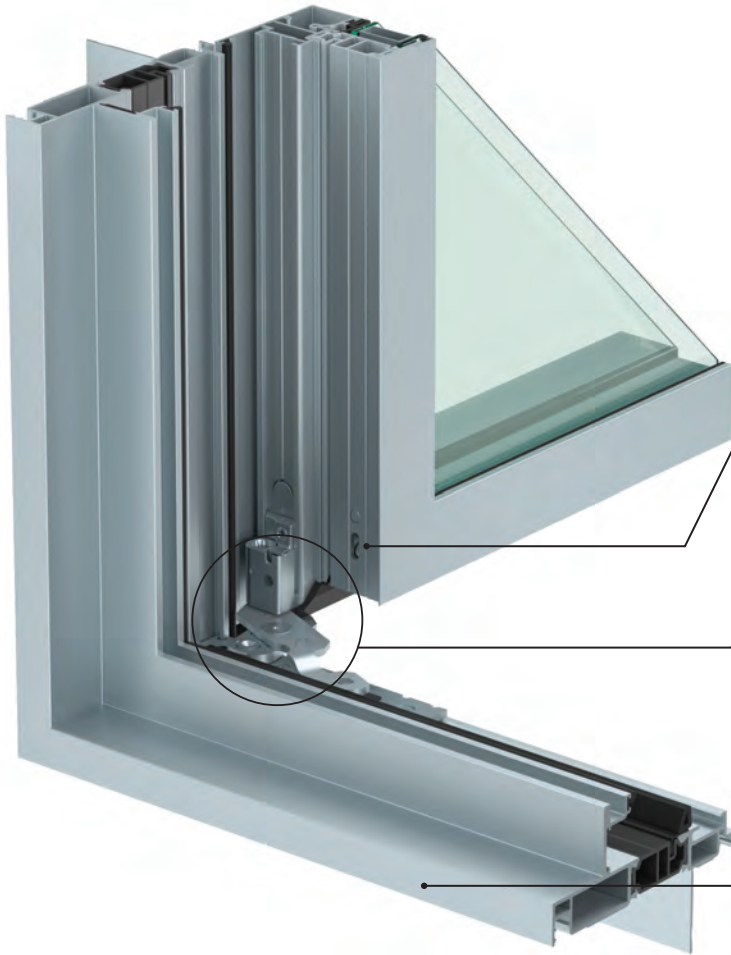

**DURABLE CORNER KEYS**

Mechanically fastened corners are kept square by cast metal corner keys. Corners are made water-tight by the injection of sealant in all corners.

**CONCEALED HINGE**

Completely concealed hinge provides the cleanest interior and exterior available. Hinges have a 320-lb weight capacity, allowing for industry-leading sizes up to 10' in height.

**MINIMAL INTERIOR JAMB**

The narrow jamb face easily disappears into surrounding wall materials.



**INDUSTRY LEADING VENTING SIZES**

42" x 120"

# A W N I N G S

## FRESH AIR WITH REFRESHING FULL-WALL VIEWS.

Optimal for ventilation on sunny and rainy days alike, awning windows can be used alone or combined with other types of windows to create the aesthetics and functionality you desire.

---

The ideal way to add airflow and architectural beauty to your space. With a high-visibility screen and the largest operating sash in the industry, awnings in the VUE Collection effectively deflect the most severe weather conditions while the 4-bar German hinges deliver years of hassle-free operation.





---

**THERMALLY ADVANCED FRAME SYSTEM**

Polyamide thermal break minimizes transference of temperature through the frame.

---

**OVERLAPPING SASH DESIGN**

The sash overlaps the frame and has three separate sealing points to keep out the elements.

---

**COMMERCIAL GRADE 4-BAR HINGE**

Corrosion-resistant stainless steel construction with an adjustable, self-balancing stay mechanism built in.



# HINGED PATIO DOORS

## CREATE FLOOR- TO-CEILING VIEWS.

Hinged patio doors make a beautiful statement in any home.

The VUE Collection hinged door combines a modern aesthetic with performance enhancements engineered to stand up to the harshest environments. Hinged doors are designed to seamlessly connect with other VUE window products.



Achieve that steel door look with the addition of a simulated lock box. Available in custom heights with and without SDL.



DOUBLE OUTSWING DOOR MULLED TO DIRECT SET WINDOWS





Inswing shown with beveled bead

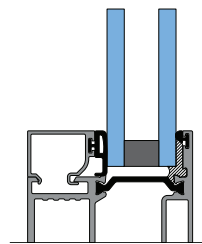

SQUARE BEAD

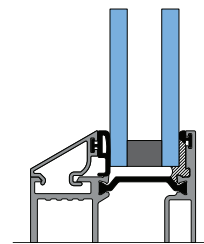

BEVELED BEAD

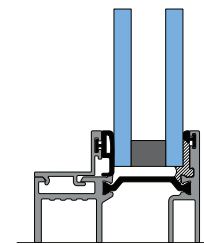

NARROW BEAD

### THREE DISTINCT EXTERIOR GLAZING BEAD OPTIONS

Match your architectural style to one of three distinct exterior aesthetics. Available in both inswing and outswing doors.



### MULTI-DIRECTIONAL HINGE

Hinges can be adjusted in all axis (up/down, side to side, in to out).

### FIVE POINT LOCKING SYSTEM

Stainless steel multi-point lock system secures the door panel in five places, for the ultimate in safety and security.

### WEPT SILL SYSTEM

Internal sill drainage keeps water away from the interior of the home. A molded sill end cap creates a watertight seal between the side jambs.

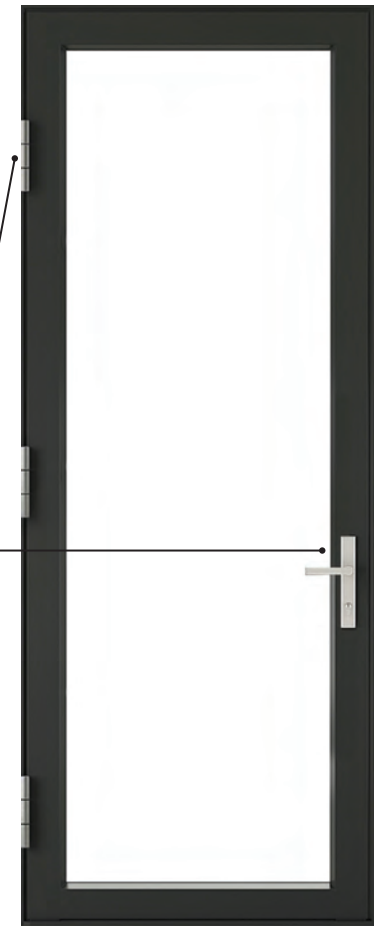

# SLIDING PATIO DOORS

## LIGHT-DRENCHED LIVING SPACES.

Sliding patio doors can fill a room with natural light changing the feel of any home.

---

A modern take on a traditional sliding patio door. Narrow profiles, engineered to perform even with larger 6-0 x 12-0 panel sizes. Create large walls of glass without the cost or deep wall depths needed for multi-slide systems.



4-PANEL SLIDING DOOR WITH DIRECT SET WINDOWS

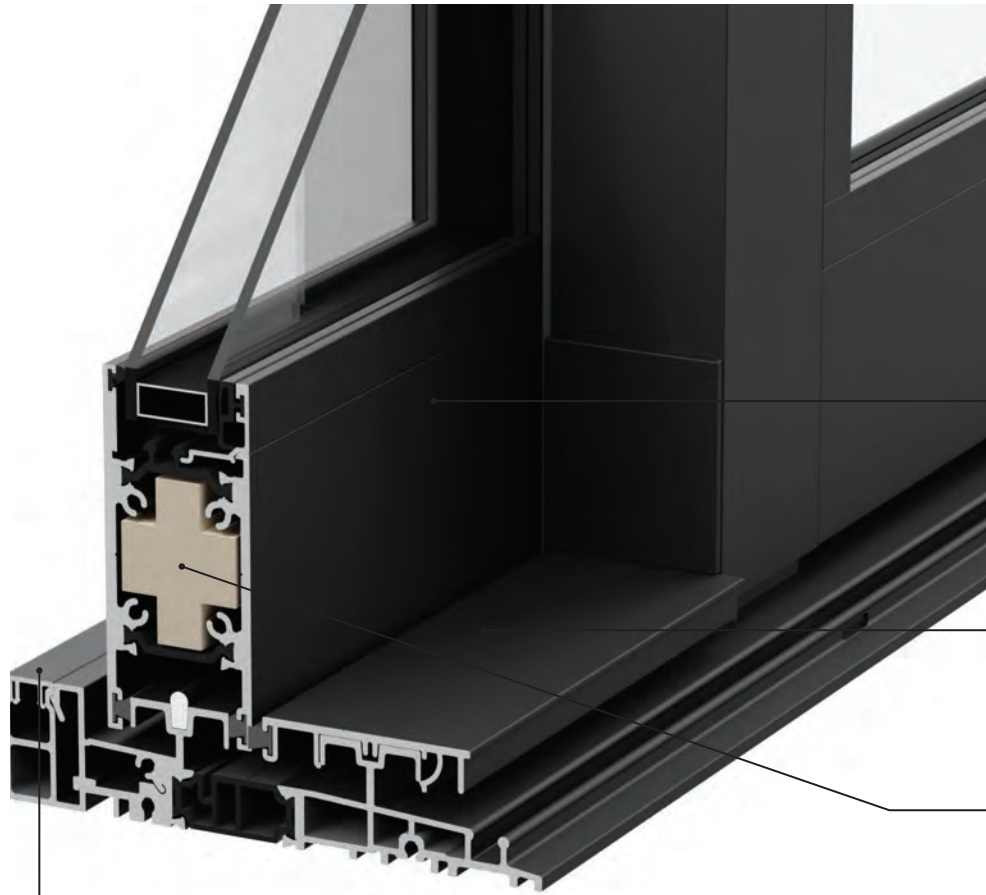

### UPGRADABLE INTERIOR SILL STOPS

Depending on your performance requirements, sill risers can be added to improve water performance. These can be easily added after the door is installed if needed.

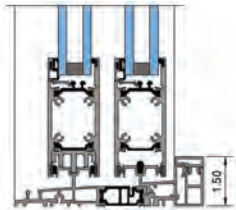

1-1/2" SILL RISER  
No Performance Rating

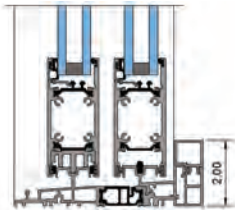

2" SILL RISER  
Tested to DP20

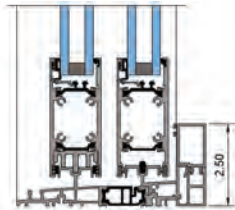

2-1/2" SILL RISER  
Tested to DP25 - DP40



### PRECISION BEARING QUAD ROLLERS

Eight (8) precision bearing rollers per door panel deliver smooth operation. Rollers are end adjustable with adjustment holes concealed by a cap on the side of the panel.

### STATIONARY PANEL SILL FILLER

Unused panel pockets and sill tracks are concealed from view with an aluminum snap in cover creating a clean aesthetic.

### FOAM FILLED PROFILES

All panel profiles are filled with rigid foam for improved thermal performance.

### LARGER PANELS

Create walls of glass with larger 6'-0" x 12'-0" nominal panel size.

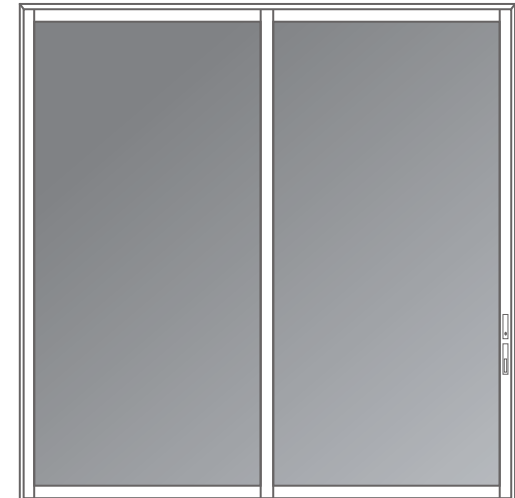

# MULTI-SLIDE DOORS

## INSIDE IS THE NEW OUTSIDE.

Moving glass walls open massive spans to create living spaces that flow effortlessly onto outdoor lounging areas.

---

Accent the connection between a home and its surroundings. Multi-slide doors offer the unique ability to open massive spans to the outdoors and create unforgettable spaces that let your imagination soar.



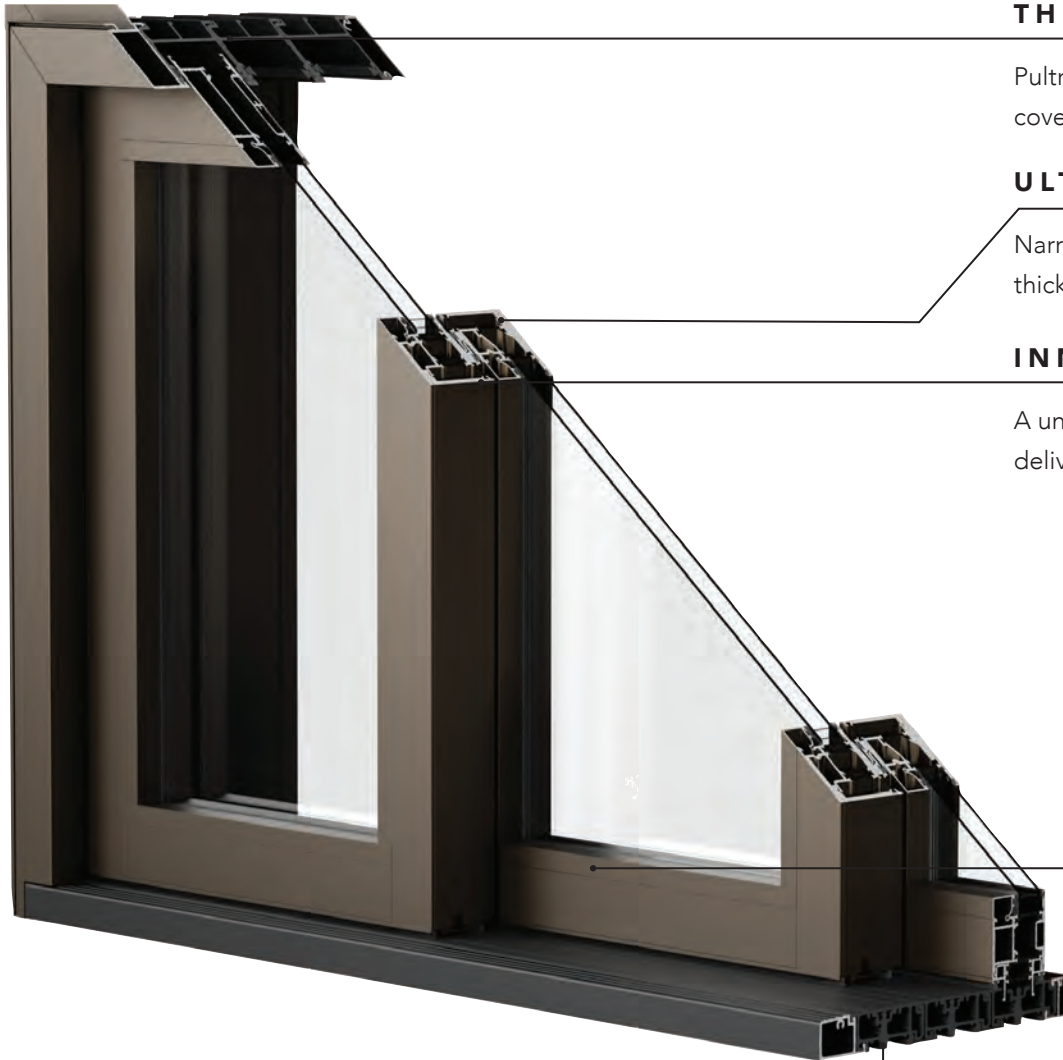

**THERMALLY ADVANCED FRAME SYSTEM**

Pultruded fiberglass sub-frame with aluminum interior and exterior covers provides optimal thermal efficiency.

**ULTRA-NARROW STILE AND RAIL PROFILES**

Narrow 2.5" wide stiles and rails maximize views while the 2.25" panel thickness ensures enduring strength.

**INNOVATIVE THERMAL-BREAK DESIGN**

A unique polyamide design helps prevent thermal bowing while delivering exceptional thermal and structural performance.



QUAD ROLLER\*

**PRECISION BEARING QUAD ROLLERS**

Eight precision bearing rollers per door panel deliver effortless operation even with the largest panels. Fully adjustable rollers ensure the highest levels of performance.

\* Smaller width panels require dual rollers instead of a quad

**AVAILABLE SILL OPTIONS**



STANDARD WEPT SILL 1.25"



STANDARD WEPT SILL WITH 1.5" RISER



STANDARD WEPT SILL WITH 2" RISER



STANDARD WEPT SILL WITH 2.5" RISER



BARRIER-FREE SILL

# PIVOT DOORS

## ELEVATE YOUR ENTRANCE.

The pivot door transforms entrances with versatile design and dramatic impact.

---

Pivot doors redefine the concept of traditional doors with their expansive range of sizes and designs. These doors create a striking entrance every time, offering the flexibility to incorporate larger architectural elements that enhance any space.



## PIVOT DOOR PANEL COLLECTIONS

We offer a variety of pivot door panel designs, featuring sleek aluminum options along with our distinctive artisan wood and metal collections, allowing you to create something truly unique.



ALUMINUM PANEL  
Thermally-broken stile and rail door

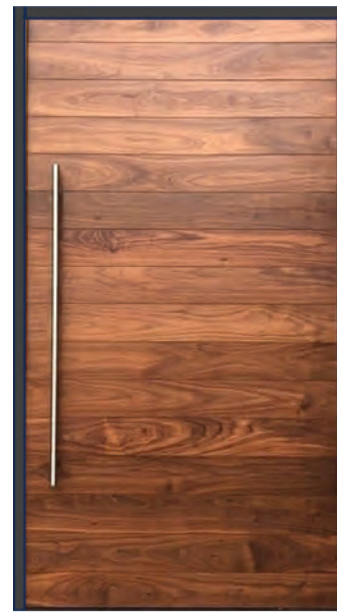

ARTISAN WOOD PANEL  
Hardwood with engineered aluminum core



ARTISAN METAL PANEL  
Atomized metal applied to engineered door panels

## FritsJurgens® SYSTEM M+

**Ease of Operation.** Even the largest panels operate with little effort.

**Concealed Mechanism.** Does not require an invasive installation, mounted into the floor.

**Damper Control.** Ensures a smooth and elegant closing movement and protects the door from touching walls.

**30 Degree Speed Control.** Allows you to determine the speed of the last part of the closing movement..

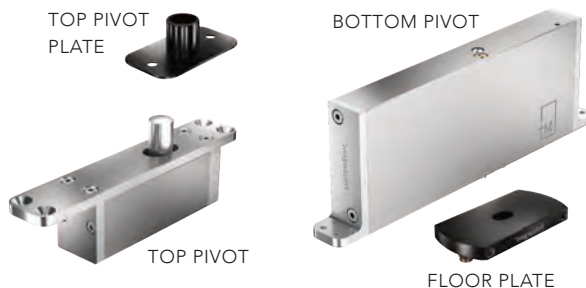

### HIGH-PERFORMANCE GLASS

Choose from a full range of high-performance insulated glass, including triple glazed.

### THREE GLAZING BEAD OPTIONS

Match your architectural style to one of three distinct exterior aesthetics.

### THERMALLY ADVANCED FRAME AND PANEL

Polyamide thermal breaks minimizes the transfer of temperatures to inside of the home.

### ADA COMPLIANT SILL

Available with no sill or 1/2" ADA Thermally broken sill.

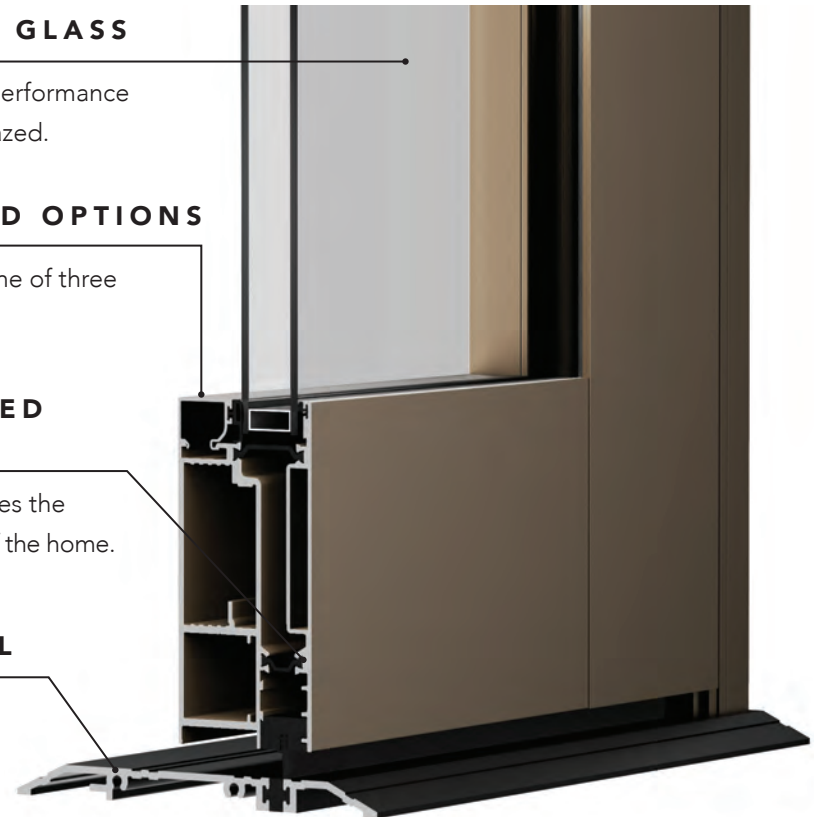

# COLORS

## A FRAME WORTHY OF THE VIEW.

Pick from our curated color and finish options or color match to any custom colors you can imagine.

---

Whether you want windows that are nearly invisible or a powerful outline to elevate any picturesque landscape, we offer the color choices and customized options to make your views stunning. Architecturally-rated finishes will ensure your windows maintain their original appearance with minimal upkeep.





# COLOR OPTIONS (INTERIOR AND EXTERIOR)

## ANODIZED ALUMINUM FINISHES



CLEAR CHAMPAGNE LIGHT BRONZE MEDIUM BRONZE DARK BRONZE BLACK

## 60 AAMA 2605 PAINTED FINISHES, 6 ANODIZED FINISHES, ALL AT THE SAME PRICE!

Color compatibility with all Weather Shield products.

## SPLIT FINISHES

Create a custom look by varying the interior and exterior colors.

## CUSTOM COLOR MATCHING

If you're looking for a truly original finish, choose from our custom color-match option.

## 60 PAINTED FINISHES



WHITE ALABASTER PAMPERED PEACH CAMEO PEARL MODERATE WHITE LINEN ACCESSIBLE BEIGE TAN SANDSTONE DESERT TAN SUPERIOR BRONZE



DRIFTWOOD MOSS BRONZE GREEN SHALE HERITAGE BROWN ADOBE VITAL YELLOW SUNBEAM YELLOW RESTRAINED GOLD SALT MARSH TIMBERIDGE AUTUMN LEAF



STREAMLINE GRAY MIST GREY GRAY MATTERS STONE GRAY PRESTIGE CHARCOAL GUNPOWDER OLYMPUS WHITE AEGEAN BLUE DISTANCE BLUE STONE INDIGO



DARK NIGHT SHORELINE ARCADIAN SAGE GREEN OCEANSIDE BLUE HILL WOODLAND GREEN BERCORTIZ GREEN HARTFORD GREEN BLACK FOREST TUDOR HOUSE QUAKER BRONZE



CRAFTSMAN BRONZE SUNDRIED TOMATO BRICK RED FIREBRICK BOYSEN-BERRY ROYAL BROWN APPALACHIAN OBSIDIAN JET BLACK WARM SILVER ANTIQUE SILVER ESPRESSO

## RADIANT METALLIC



VUE COLLECTION

Finishes and colors shown may not be actual representations. Please visit authorized Weather Shield dealer for color samples.

# HARDWARE

## FIT FOR A PERSONAL TOUCH.

A minimal profile with maximum elegance. The variety of finish options guarantee every piece of hardware will blend seamlessly with your overall design.

---

To accompany the narrow profiles in the VUE Collection, each hardware option offers a complementary sleek design. Tested to withstand frequent use for years to come, intuitive latches and comfortable ergonomics make operation effortless.



Image Courtesy by PDET Photography  
Designed & Built by Airoom Architects Builders & Remodelers

## CASEMENT AND AWNING HARDWARE OPTIONS AND FINISHES

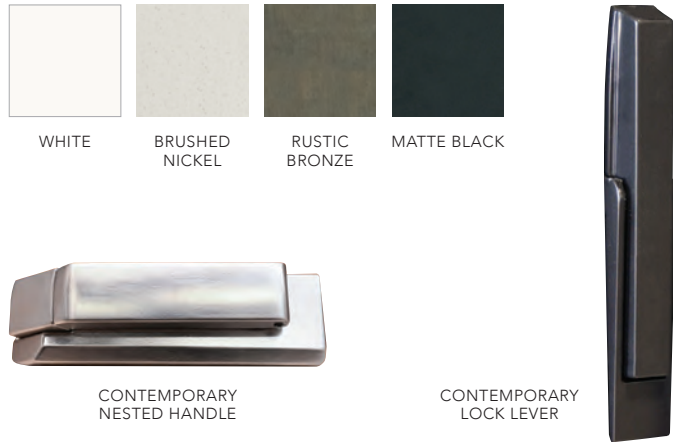

## CONCEALED SCREEN FRAME

A unique low-profile screen frame is completely concealed within a channel in the window. The high-visibility screen mesh delivers the highest screen cloth transparency available.

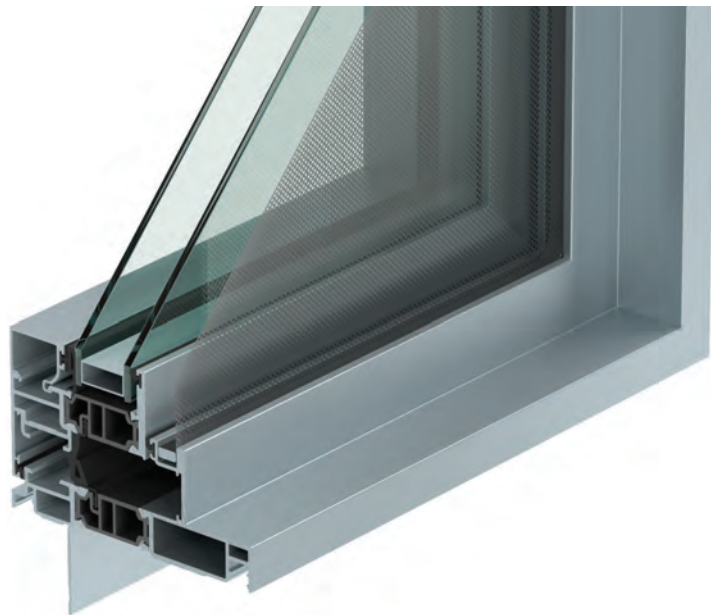

## DOOR HARDWARE AND FINISHES



## HINGED DOOR



## MULTI-SLIDE DOOR



## SLIDING DOOR



# GLASS & DIVIDED LITES

## TAILORED TO LIFE AND STYLE.

Designed to improve any home's energy efficiency, our glass options work to protect your home in any climate and enhance your comfort.

---

Meanwhile, Simulated Divided "Lites" (SDL) offer a custom, authentic look of true divided light without sacrificing energy efficiency.



## GLASS OPTIONS

Choosing the right glass is critical for optimal performance, which is why the VUE Collection glazing options exceed even the most stringent energy codes. Black spacer bars minimize visual distractions while adding depth for a clean finishing touch.

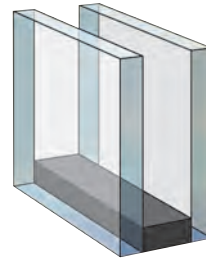

**INSULATED LOW-E  
ALL CLIMATE**  
(Cardinal LoE<sup>2</sup>-272)

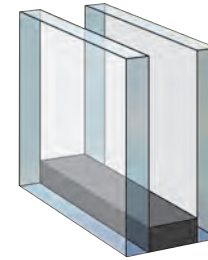

**Zo-e-shield 5**  
ULTIMATE SOLAR CONTROL  
(Cardinal LoE<sup>3</sup>-366)

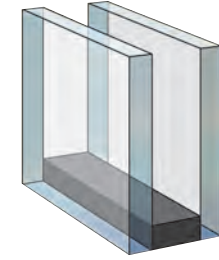

**Zo-e-shield SE**  
PLUS ROOM SIDE LOW-E  
(Cardinal LoE<sup>3</sup>-366 / LoE-i89)

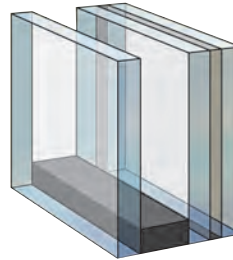

**Zo-e-shield 6**  
LAMINATED INTERIOR  
(Cardinal LoE<sup>3</sup>-366 w/Lami)

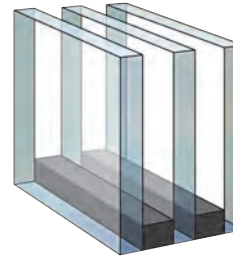

**Zo-e-shield 7**  
5 COATS OF LOW-E  
(Cardinal LoE<sup>3</sup>-366 w/ LoE<sup>2</sup>-272)

## SIMULATED STEEL APPEARANCE

Combine Beveled SDL and Beveled Bead for an authentic steel look with superior aluminum performance.

## SIMULATED DIVIDED LITE (SDL) OPTIONS



7/8" BEVELED SDL BAR



7/8" SQUARE SDL BAR

Direct-set with  
beveled bead  
and bar



\*Beveled Bead and SDL not available on Sliding Door

# SERVICES & LOGISTICS

GREAT IDEAS.  
IDEAL RESULTS.

From your initial design through the final installation, our team is ready to support you every step of the way.

---

Let us focus on what we do best so you can put your energy into what you do best. Our engineers, custom craftsmen and extensive support services are here to help you make decisions, streamline orders and create views you'd have to see to believe.

**800.826.1608**

**[vue.support@weathershield.com](mailto:vue.support@weathershield.com)**



IMAGE COURTESY OF KEITH ISAACS PHOTOGRAPHY



## Design Assistance

Picking the right products for your application is essential to ensure the success of a project. Our technical specialists are here to provide you with drawings and specifications to help your vision become a reality.



## Code Compliance

The VUE Collection products have been certified by an independent laboratory for thermal and structural performance. Our architectural support team will help with the selection of the right options to ensure compliance with even the most stringent codes.



## Logistics

We work with our expert dealer partners and in-field installation teams to develop a logistics strategy that ensures our products are well protected and ready for installation.



## Installation

Our network of trusted dealers work collaboratively with our manufacturing and your on-site team to ensure a seamless, high-quality installation. Included with every order, the VUE Collection™ Job Boxes contain all the smaller items you'll need for installation in one convenient place.

VUE  
COLLECTION®

**WEATHER SHIELD.**  
WINDOWS & DOORS

**800.222.2995**

**WEATHERSHIELD.COM**

©2024 Weather Shield Mfg, Inc.

1308904 – 08/24



Image Courtesy by PDET Photography  
Designed & Built by Airoom Architects Builders & Remodelers